

F33 AS

33 Series

- 28 HP
- Air Cooled
- 2-Stroke
- Light weight
- Best suited for light aviation and powered parachutes



DESCRIPTION

Where the weight could be an issue.

The 33 Series air cooled two-stroke engines offer the ultimate power-to-weight ratios available in the 28-horsepower market.

Makes the best choice for use in light and ultralight aviation, powered parachutes and all applications where weight could be an issue.

Provides a time between overhauls of 1000 hours, the 33 Series is incredibly lightweight and ready to power your aviation dreams.



F33 AS

33 Series



TECHNICAL SPECIFICATION:

TYPE:	Single cylinder two stroke	WEIGHT:	12,7 kg (28 lb)
DISPLACEMENT:	312 cm³ (19,1 in³)	LENGTH:	299,5 mm (11,79 in)
STROKE:	69 mm (2,72 in)	WIDTH:	380 mm (14.96 in)
BORE:	76 mm (2,99 in)	HEIGHT:	300 mm (11.81 in)
MAX. PERFORMANCE:	20,6 kW (28 HP) at 6500 rpm (AS) According DIN 70020	STARTING DEVICE:	Recoil starter
MAX. TORQUE:	32,3 Nm (23,8 ft.lb) at 5800 rpm (AS)	RUNNING DIRECTION:	Counter-clockwise , view to output shaft
CARBURATION:	Float type carburator	COOLING:	Air Cooling
FUEL MIXTURE:	Mixture 1:50 , 2-stroke-oil, fuel min. 95 octane (RON) Mixture 1:80-100 with BLUEMAX 2-stroke-oil, fuel min. 95 octane	IGNITION SYSTEM:	CDI

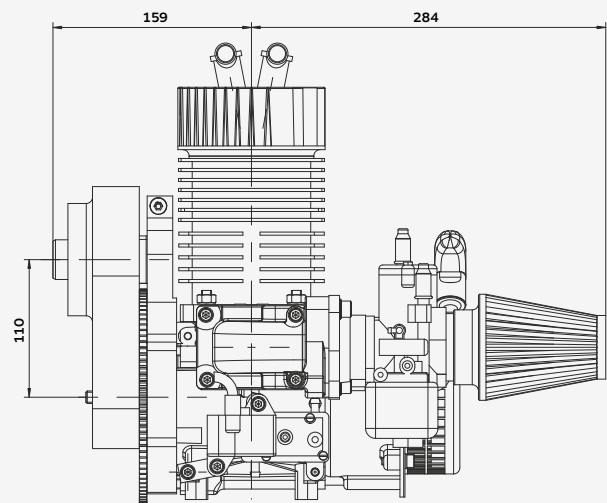
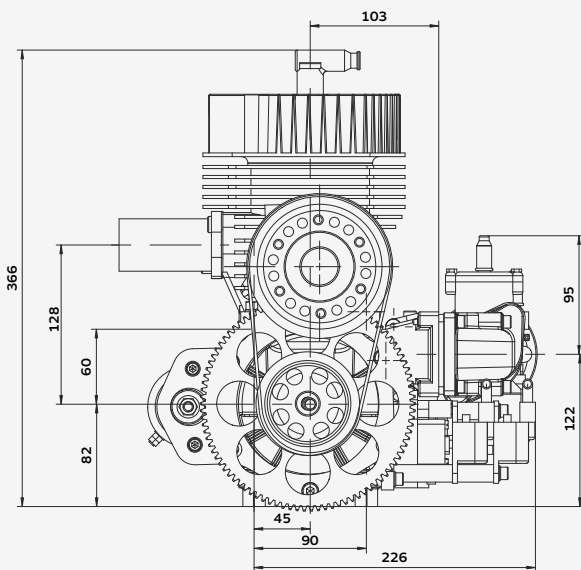

OPTIONS

- Dual ignition
- 50 W generator power
- Belt reduction G33 (1:1,8 / 1:2,2 / 1:2,5)
- Electric starter (only in combination with G33)
- Cylinderhead Maximo

Hirth is a registered trademark of Hirth Engine GmbH. All rights reserved. This is not a certificated aircraft engine! It has not received the safety and durability testings specified by aircraft standards. It is only for use in uncertificated experimental aircraft or vehicles when there is no risk for the safety due to an engine failure. Never fly the aircraft equipped with this engine in circumstances or in areas, in weather-conditions or in altitudes where you have no chance for successful landing after an engine failure. The user is taking all risk resulting from the use of this engine and he is aware of the possibility of sudden functional disturbances. www.hirthengines.com



AUTHORIZED HIRTH ENGINE DISTRIBUTOR FOR NORTH AND CENTRAL AMERICA
 11160 SW Durham Lane, Suite 1 | McMinnville, OR 97128
 Office: 503.434.6845 | Fax: 503.217.6080 | www.nwuav.com



The materials contained in this brochure are provided for information only, "as is" without any warranties, express or implied, including warranties of merchantability, fitness of purpose and non-infringement of third-party intellectual property. While every effort is made to ensure that the information and specifications are accurate, the scope of information is limited by nature. NWUAV Propulsion Systems reserves the right to make changes to the Products described in the Product Brochure at any time, without notice. The application of our products is dependent upon the operating mission, environmental conditions, loads and other factors; none of which can be ascertained by this brochure. Any technical advice or information gleaned from this Product Brochure is given in good faith and without charge, and said advice and information is provided by NWUAV Propulsion Systems without assumption of liability or obligation. This brochure and the information it contains is the work product of NWUAV Propulsion Systems ("NWUAV"). All title, ownership rights and intellectual property rights in and relating to this brochure is owned by NWUAV or used by NWUAV through pre-authorization by third parties and cannot be used without its express prior written permission.