

Overview

ping1090i is the world's smallest, lightest and most affordable full range, dual link Automatic Dependent Surveillance – Broadcast (ADS-B) transceiver with integrated Satellite Based Augmentation System (SBAS) Global Positioning System (GPS) and precision barometric sensor. At just 26 grams, it assists with Detect and Avoid (DAA) for Unmanned Aircraft Systems (UAS) operations in the National Airspace System (NAS). ADS-B IN on 1090 MHz and 978MHz. ADS-B OUT on 1090MHz. Approved for use in the United Kingdom and Australia as Electronic Conspicuity Device (ECD).

Features

Transceiver

- Detects ADS-B equipped aircraft on 1090MHz and 978MHz within a 100-statute mile radius in real time
- Transmits ADS-B DF-18 on 1090MHz Extended Squitter
- GDL 90 combined UAT / 1090ES traffic reports
- SMA 978/1090MHz Antenna Connector, 1090MHz Antenna Included

GPS

- Integrated high integrity SBAS GPS sensor (derived from uAvionix's TSO C-199 FYX technology)
- Integrated GPS antenna
- Integrated precision, temperature controlled static pressure sensor accurate to 80,000ft.
- Battery backed GPS for fast Time-to-First-Fix (TTFF)
- GPS/SBAS augmentation system. RAIM layer for Fault exclusion.

Interface

- GDL 90/Mavlink control serial input compatible with popular autopilots
GDL 90 ownship and altitude packets

Regulatory

- UK CAA CAP 1391 "Basic Device" Approved
- AUS CASA CAO 20.18 "Basic Device" Approved
- EU CE/RED Declaration of Conformity 2014/53/EU



Technical Specifications

Specification	Value
Input Power	11-28V
	500mW Ave.
	30W Peak (400us)
Size	25x40x16mm
Weight	26grams
SIL/SDA	1/1 (or 1/0 for CAP1391 devices in UK only)
Operating Temp	-45 to 70°C
Transceiver	
Transmit	
1090MHz	20W Nominal (43dBm)
Receive	
MTL 1090MHz	-88dBm
Dynamic Range	-79 to 0dBm
MTL 978MHz	-93dBm
Dynamic Range	-90 to -3dBm
WAAS GPS	
Augmentation	SBAS
Sensitivity	-166dBm
Altimeter	
Range	-1000ft - 80,000ft
Interfaces	
COM1 - 4 pin	
Control	57600bps GDL 90/Mavlink
Ownship	57600bps GDL 90/Mavlink
COM2 - 5 pin	
Programming	115200bps GDL 90

DISTRIBUTOR  Northwest UAV <small>A GLOBAL COMPANY</small>	+1 503.434.6845 +1 503.217.6080 customerservice@nwuav.com www.nwuav.com
	11160 SW Durham Lane, Suite 1 McMinnville, OR 97128 USA

uAvionix reserves the right to alter product, services offerings, specifications, and pricing at any time without notice.

© Copyright 2021 uAvionix, all rights reserved. www.uavionix.com

Electrical Specification

Programming Interface

Pin	Type		
1	Input	UTC	
2	Input	RXD	MavLink
3	Output	TXD	GDL90
4	Power	5V	
5	Ground	Ground	

Mating Connector: JST ZHR-5

Pins: SZH-002T-P0.5

Indicators

LED	ON	FLASHING
BLUE		
GREEN		UAT/1090 Traffic
RED	FAULT	Transmit

Power Interface

Pin	Type	
1	Power	11-28V
2	Ground	

Mating Connector: Molex 0436450200

Pins: 0462350001

Data Interface

Pin	Type		
1	Input	RXD/SDA	MavLink
2	Output	TXD/SCL	MavLink
3	Power	5V	
4	Ground		

Mating Connector: JST ZHR-4

Pins: SZH-002T-P0.5

Mechanical Specification

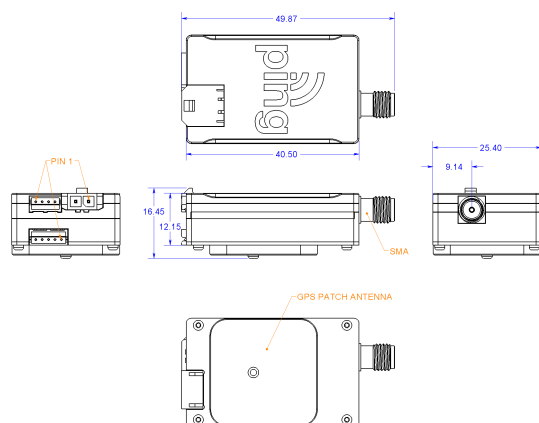

Programming and Configuration

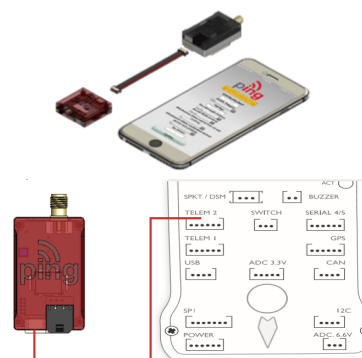

Any antenna certified to TSO-C66, TSO-C74, TSO-C112 with a peak gain of 4 dBi or less, a omni-directional radiation pattern, and a VSWR of 1.8 or less at 1090MHz is approved for use with this device and will ensure conformance to all applicable standards for RF emissions.

Modifications and Use Outside of Intended Scope

This device has been design and tested to conform to all applicable standards in the original form and when configured with the components shipped with the device. It's not permissible to modify the device, use the device for any use outside of the intended scope, or use the device with any antenna other than the one shipped with the device.

Important Pilot Advisory Note Regarding Safety of Radio Frequency Energy

Safe use of this device requires care as to the placement of the antenna. Place the antenna at least 4cm away from any part of your body or that of other cabin occupants. To stop all RF emissions, remove power from the equipment. Only handle the antenna when power is disconnected. Advise your passenger(s) to avoid contact with the antenna while power is applied to the equipment. Retain these instructions with your maintenance logs/files and for future reference.

Warning: This transceiver is to be used to improve pilot situational awareness only and as a navigational aid. It is not intended for use in IFR flight conditions. uAvionix is not responsible for the transceiver's end use and will not be held liable for any events occurring from its use.

The following required statement from the Federal Communications Commission (FCC) applies to United States based entities with the exception of direct sales to the U.S. Government and units directly exported by uAvionix:

This device has not been authorized as required by the rules of the Federal Communications Commission. This device is not, and may not be, offered for sale or lease, or sold or leased, until authorization is obtained.

uAvionix reserves the right to alter product, services offerings, specifications, and pricing at any time without notice.

© Copyright 2021 uAvionix, all rights reserved. www.uavionix.com