

## Overview

ping2020i is the world's smallest, lightest and most affordable full range, dual link Automatic Dependent Surveillance - Broadcast (ADS-B) UAT transceiver with integrated Satellite Based Augmentation System (SBAS) Global Positioning System (GPS) and precision barometric sensor. At just 26 grams, it assists with Detect and Avoid (DAA) functionality for Unmanned Aircraft Systems (UAS) operations in the National Airspace System (NAS). ADS-B IN on 1090MHz and 978MHz. ADS-B OUT on 978MHz.



## Features

### Transceiver

- Detects ADS-B equipped aircraft on 1090MHz and 978MHz within a 100-statute mile radius in real time
- Transmits ADS-B on 978MHz
- Combined UAT / 1090ES traffic reports
- SMA 978/1090MHz Antenna Connector. Antenna included.

### GPS

- Integrated high integrity SBAS GPS sensor
- Integrated GPS antenna
- Integrated precision, temperature controlled static pressure sensor accurate to 80,000ft
- Battery backed GPS for fast Time-to-First-Fix (TTFF)
- GPS/SBAS augmentation system with RAIM layer for Fault Detection and Exclusion

### Performance

- Mavlink control serial input compatible with popular autopilots
- GDL 90 ownship and altitude packets
- Meets RTCA DO-282B Class B1S
- Meets RTCA DO-260B Class A0
- Meets RTCA DO-160G sections 4 and 5

## Regulatory

- FCC ID: 2AFFTUAT016

## Technical Specifications

| Specification                       | Value               |
|-------------------------------------|---------------------|
| Input Power                         | 11-28V              |
|                                     | 500mW Ave.          |
|                                     | 30W Peak (400us)    |
| Size                                | 25x40x16mm          |
| Weight                              | 26grams             |
| SIL/SDA                             | 1/1                 |
| Operating Temp                      | -45 to 70°C         |
| <b>Transceiver</b>                  |                     |
| <i>Transmit</i>                     |                     |
| 978MHz                              | 20W Nominal (43dBm) |
| 1090MHz                             | S/W Disabled        |
| <i>Receive</i>                      |                     |
| MTL 1090MHz                         | -88dBm              |
| Dynamic Range                       | -79 to 0dBm         |
| MTL 978MHz                          | -93dBm              |
| Dynamic Range                       | -90 to -3dBm        |
| <b>WAAS GPS</b>                     |                     |
| Augmentation                        | SBAS                |
| Sensitivity                         | -166dBm             |
| <b>Altimeter</b>                    |                     |
| Range                               | -1000ft - 80,000ft  |
| <b>Interfaces</b>                   |                     |
| <i>Data Interface</i>               |                     |
| Control                             | 57600bps Mavlink    |
| Ownship                             | 57600bps Mavlink    |
| <i>Programming Interface</i>        |                     |
| Programming                         | 115200bps GDL 90    |
| <b>Options</b>                      |                     |
| 978MHz Transceiver Antenna Included |                     |

**DISTRIBUTOR**



**Northwest UAV**  
A GLOBAL COMPANY

+1 503.434.6845  
+1 503.217.6080  
customerservice@nvwuav.com  
[www.nvwuav.com](http://www.nvwuav.com)

11160 SW Durham Lane, Suite 1 | McMinnville, OR 97128 USA

uAvionix reserves the right to alter product, services offerings, specifications, and pricing at any time without notice.

© Copyright 2019 uAvionix, all rights reserved. [www.uavionix.com](http://www.uavionix.com)

### Quality Standards and Procedures

Designed and assembled in the U.S., HALT and HASS tested, IPC-610 class II soldering, production functional testing. Software to DO-178C Level C, Hardware to DO-254 Level C.

### Electrical Specification

#### Programming Interface

| Pin | Type   |        |         |
|-----|--------|--------|---------|
| 1   | Input  | UTC    |         |
| 2   | Input  | RXD    | MavLink |
| 3   | Output | TXD    | GDL90   |
| 4   | Power  | 5V     |         |
| 5   | Ground | Ground |         |

Mating Connector: JST ZHR-5  
Pins: SZH-002T-P0.5

#### Indicators

| LED   | ON    | FLASHING            |
|-------|-------|---------------------|
| GREEN |       | UAT /1090ES Traffic |
| RED   | FAULT | Transmit            |

#### Power Interface

| Pin | Type   |        |
|-----|--------|--------|
| 1   | Power  | 11-28V |
| 2   | Ground |        |

Mating Connector: Molex 0436450200  
Pins: 0462350001

#### Data Interface

| Pin | Type   |         |         |
|-----|--------|---------|---------|
| 1   | Input  | RXD/SDA | MavLink |
| 2   | Output | TXD/SCL | MavLink |
| 3   | Power  | 5V      | Output  |
| 4   | Ground |         |         |

Mating Connector: JST ZHR-4  
Pins: SZH-002T-P0.5

### Mechanical Specification

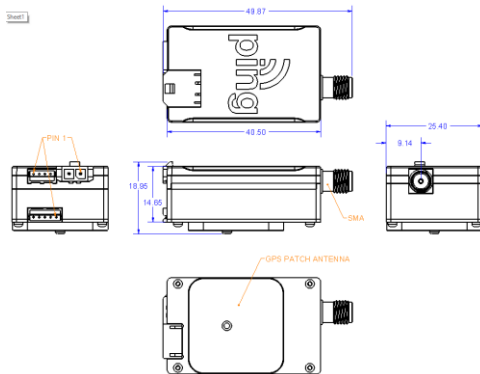

### Programming and Configuration

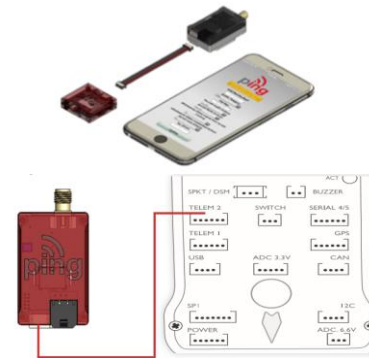

Any antenna certified to TSO-C66, TSO-C74, TSO-C112 with a peak gain of 4 dBi or less, an omni-directional radiation pattern, and a VSWR of 1.8 or less at 1090MHz is approved for use with this device and will ensure conformance to all applicable standards for RF emissions.

#### Modifications and use outside of Intended Scope

This device has been designed and tested to conform to all applicable standards in the original form and when configured with the components shipped with the device. It's not permissible to modify the device, use the device for any use outside of the intended scope, or use the device with any antenna other than the one shipped with the device.

#### Important Pilot Advisory Note Regarding Safety of Radio Frequency Energy

Safe use of this device requires care as to the placement of the antenna. Place the antenna at least 4cm away from any part of your body or that of other cabin occupants. To stop all RF emissions, remove power from the equipment. Only handle the antenna when power is disconnected. Advise your passenger(s) to avoid contact with the antenna while power is applied to the equipment. Retain these instructions with your maintenance logs/files and for future reference.

#### FCC RF Radiation Exposure Statement

This equipment complies with FCC RF radiation exposure limits (Table 1 of 47Pt1 (i) 1.1310) set forth for a Public/Uncontrolled Environment.

**Warning:** This transceiver is to be used to improve pilot situational awareness only and as a navigational aid. It is not intended for use in IFR flight conditions. uAvionix is not responsible for the transceiver's end use and will not be held liable for any events occurring from its use.